

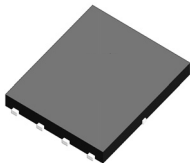

**Product Summary**

$V_{DS}$	$R_{DS(ON\_MAX)}$	$I_{D\_MAX}$
40 V	5.3 m $\Omega$ @ $V_{GS} = 10V$	65 A
	8.2 m $\Omega$ @ $V_{GS} = 4.5V$	

**PDFN5060-8L-D**



Top View

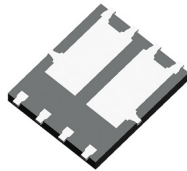

Bottom View

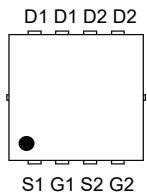

PIN Configuration (Top View)

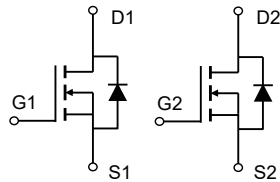

Chip-1 & Chip-2 Schematic Diagram

**Features**

- Low On-Resistance
- Excellent FoM (figure of merit)
- 100% UIS and  $R_g$  tested



**Application**

- Automotive Applications
- Switching Applications
- Motors, Lamps and Solenoid Control

**Mechanical Data**

- Green Molding Compound
- Moisture Sensitivity: Level 1 per J-STD-020
- UL Flammability Classification Rating 94V-0

**Ordering Information**

Orderable Part Number	Package Type	Device Marking	Form	Quantity (pcs)
CMT4005ALPD	PDFN5060-8L-D	4005ALD	13" Tape&Reel	5,000

**Maximum Ratings** (@  $T_C = 25^\circ C$ , unless otherwise specified.)

Parameter	Symbol	Value	Unit
Drain - Source Voltage	$V_{DS}$	40	V
Gate - Source Voltage	$V_{GS}$	$\pm 20$	V
Continuous Drain Current ( $V_{GS} = 10V$ ) <sup>(1)</sup>	$I_D$	$T_C = 25^\circ C$	65
		$T_C = 100^\circ C$	41
Pulsed Drain Current <sup>(2)</sup>	$I_{DM}$	260	A
Single Pulse Avalanche Energy <sup>(3)</sup>	$E_{AS}$	102	mJ
Single Pulse Avalanche Current (L= 0.1mH)	$I_{AS}$	27	A
Power Dissipation	$P_D$	$T_C = 25^\circ C$	37
		$T_C = 100^\circ C$	15
Junction & Storage Temperature Range	$T_J, T_{STG}$	-55 ~ +150	$^\circ C$

**Thermal Characteristics**

Parameter	Symbol	Typ.	Max.	Unit
Thermal Resistance, Junction-to-Ambient <sup>(4)</sup>	$R_{\theta JA}$	45	56	$^\circ C/W$
Thermal Resistance, Junction-to-Case <sup>(5)</sup>	$R_{\theta JC}$	2.6	3.4	$^\circ C/W$



**Electrical Characteristics(Chip-1 & Chip-2) (@ T<sub>J</sub> = 25°C, unless otherwise specified.)**

Parameter	Symbol	Test Condition	Min.	Typ.	Max.	Unit
<b>Off Characteristics <sup>(6)</sup></b>						
Drain-Source Breakdown Voltage	V <sub>(BR)DSS</sub>	V <sub>GS</sub> = 0V, I <sub>D</sub> = 250μA	40	-	-	V
Zero Gate Voltage Drain Current	I <sub>DSS</sub>	V <sub>DS</sub> = 40V, V <sub>GS</sub> = 0V T <sub>J</sub> = 125°C	-	-	1.0	μA
			-	-	100	μA
Gate-Source Leakage Current	I <sub>GSS</sub>	V <sub>GS</sub> = ±20V, V <sub>DS</sub> = 0V	-	-	±100	nA
<b>On Characteristics <sup>(6)</sup></b>						
Gate Threshold Voltage	V <sub>GS(th)</sub>	V <sub>GS</sub> = V <sub>DS</sub> , I <sub>D</sub> = 250μA	1.2	1.7	2.5	V
Static Drain-Source On-Resistance	R <sub>DS(ON)</sub>	V <sub>GS</sub> = 10V, I <sub>D</sub> = 20A V <sub>GS</sub> = 4.5V, I <sub>D</sub> = 15A	-	4.4	5.3	mΩ
			-	6.5	8.2	mΩ
Forward Transconductance	g <sub>fs</sub>	V <sub>DS</sub> = 5.0V, I <sub>D</sub> = 20A	-	25	-	S
Diodes Forward Voltage	V <sub>SD</sub>	I <sub>S</sub> = 2.0A, V <sub>GS</sub> = 0V	-	0.7	1.2	V
<b>Dynamic Characteristics <sup>(7)</sup></b>						
Input Capacitance	C <sub>iss</sub>	V <sub>DS</sub> = 20V, V <sub>GS</sub> = 0V, f = 1MHz	-	994	-	pF
Output Capacitance	C <sub>oss</sub>		-	602	-	pF
Reverse Transfer Capacitance	C <sub>rss</sub>		-	23	-	pF
Gate Resistance	R <sub>g</sub>	V <sub>GS</sub> = 0V, V <sub>DS</sub> = 0V, f = 1MHz	-	4.1	-	Ω
<b>Switching Characteristics <sup>(7)</sup></b>						
Turn-On DelayTime	t <sub>d(on)</sub>	V <sub>GS</sub> = 10V, V <sub>DS</sub> = 20V I <sub>D</sub> = 20A, R <sub>GEN</sub> = 3.0Ω	-	1.3	-	ns
Rise Time	t <sub>r</sub>		-	12	-	ns
Turn-Off DelayTime	t <sub>d(off)</sub>		-	17	-	ns
Fall Time	t <sub>f</sub>		-	12	-	ns
<b>Gate Charge Characteristics <sup>(7)</sup></b>						
Total Gate Charge (V <sub>GS</sub> = 10V)	Q <sub>g</sub>	V <sub>DS</sub> = 20V, I <sub>D</sub> = 20A V <sub>GS</sub> = 10V	-	14.3	-	nC
Total Gate Charge (V <sub>GS</sub> = 4.5V)	Q <sub>g</sub>		-	6.7	-	nC
Gate-Source Charge	Q <sub>gs</sub>		-	3.1	-	nC
Gate-Drain Charge	Q <sub>gd</sub>		-	1.8	-	nC
Gate Plateau Voltage	V <sub>plateau</sub>		-	3.2	-	V
<b>Drain-Source Diode Characteristics <sup>(7)</sup></b>						
Body Diode Reverse Recovery Time	t <sub>rr</sub>	I <sub>F</sub> = 20A, dI/dt = 100A/μs, T <sub>J</sub> = 25°C	-	30	-	ns
Body Diode Reverse Recovery Charge	Q <sub>rr</sub>		-	11	-	nC
Diode Forward Current	I <sub>S</sub>	T <sub>C</sub> = 25°C	-	-	56	A

**Notes:**

1. This current is chip limited, which is calculated based on R<sub>thjc</sub>.
2. This current is calculated on single pulse with 10μs Pulse & Duty Cycle = 1%.
3. Defined by design, not subject to production test, E<sub>AS</sub> condition: T<sub>J</sub>=25°C, V<sub>DD</sub>=20V, V<sub>GS</sub>=10V, L=1.0mH.
4. Device mounted on FR-4 substrate PC board with 2oz copper in 1inch square cooling area.
5. Thermal resistance from junction to soldering point (on the exposed drain pad).
6. Short duration pulse test used to minimize self-heating effect.
7. Defined by design, not subject to production.



Typical Electrical and Thermal Characteristics (Chip-1 & Chip-2)

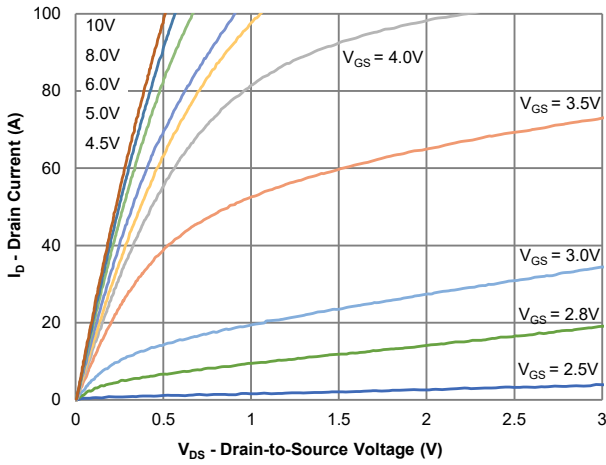

Figure 1: Output Characteristics

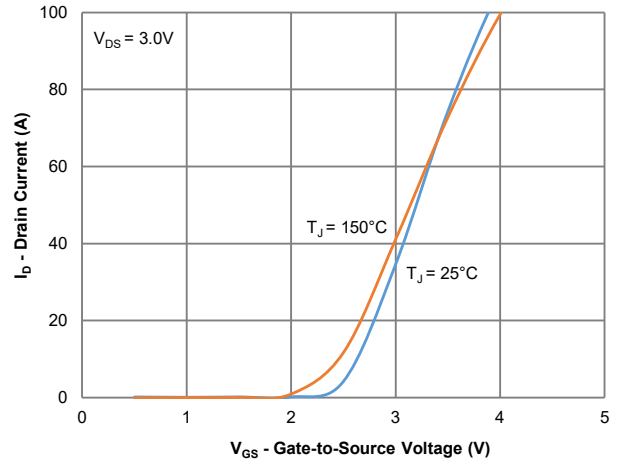

Figure 2: Transfer Characteristics

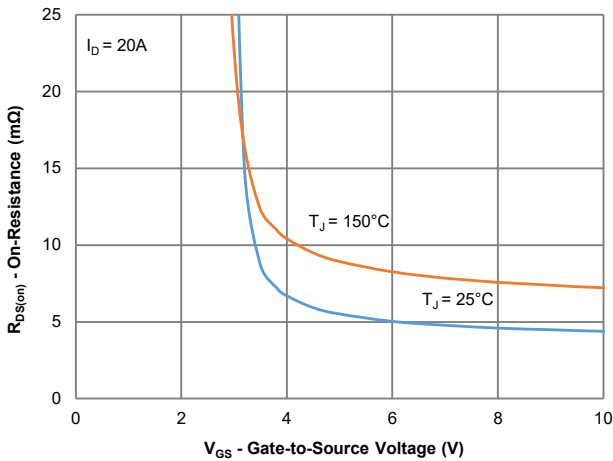

Figure 3: On-Resistance vs. Gate-Source Voltage

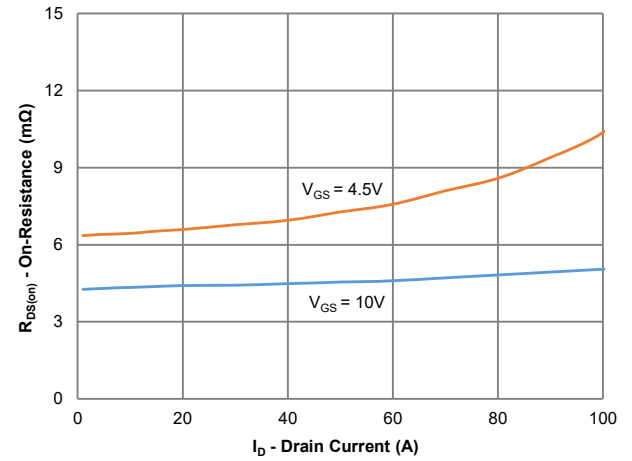

Figure 4: On-Resistance vs. Gate-Source Voltage

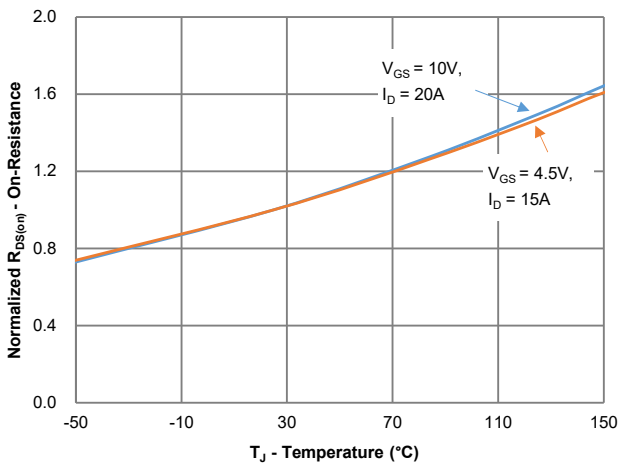

Figure 5: On-Resistance vs. Junction Temperature

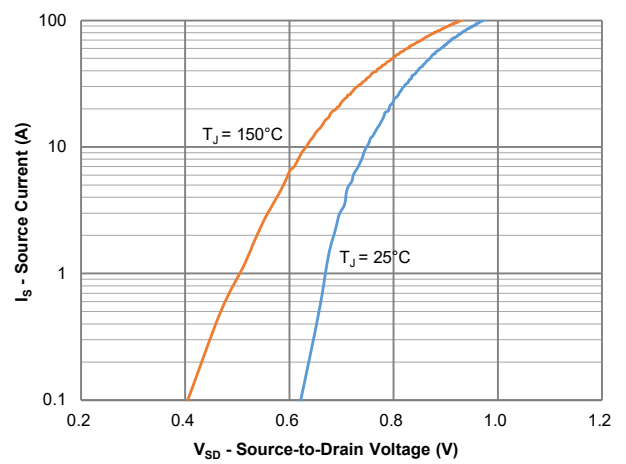

Figure 6: Source-Drain Diode Forward Voltage



Typical Electrical and Thermal Characteristics (Chip-1 & Chip-2)

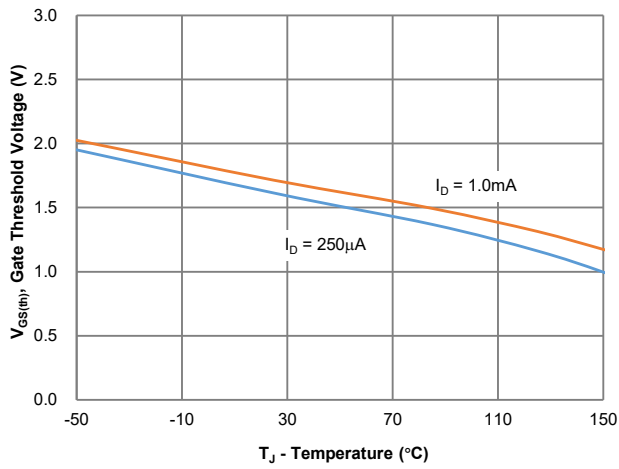

Figure 7: Gate Threshold Variation vs. Junction Temperature

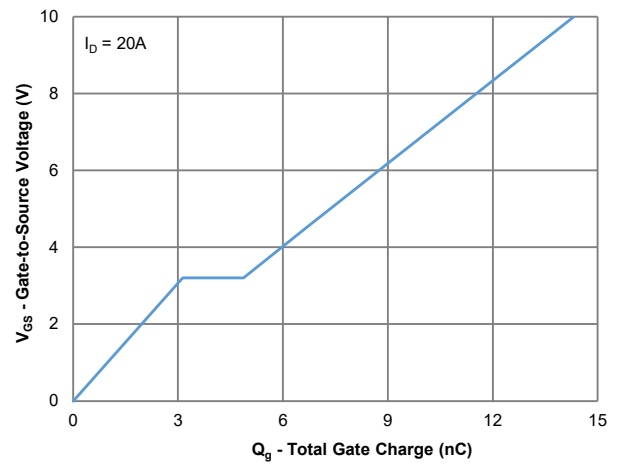

Figure 8: Gate Charge Characteristics

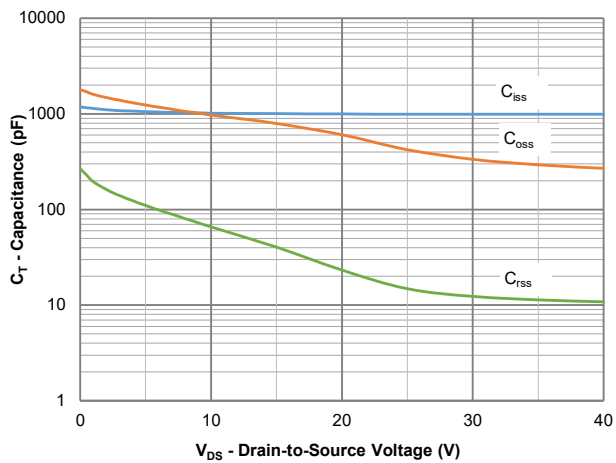

Figure 9: Capacitance Characteristics

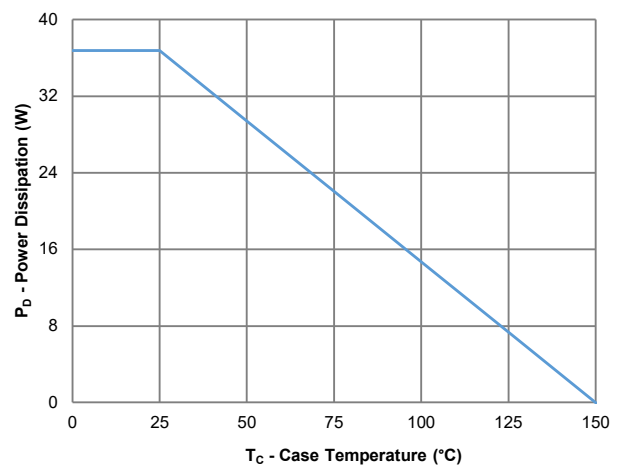

Figure 10: Power Derating

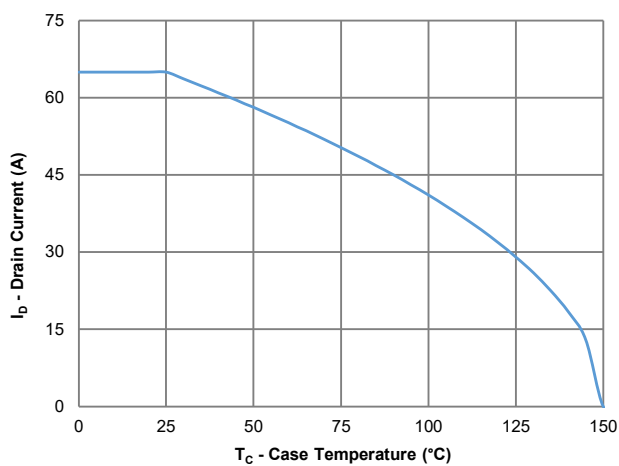

Figure 11: Current Derating

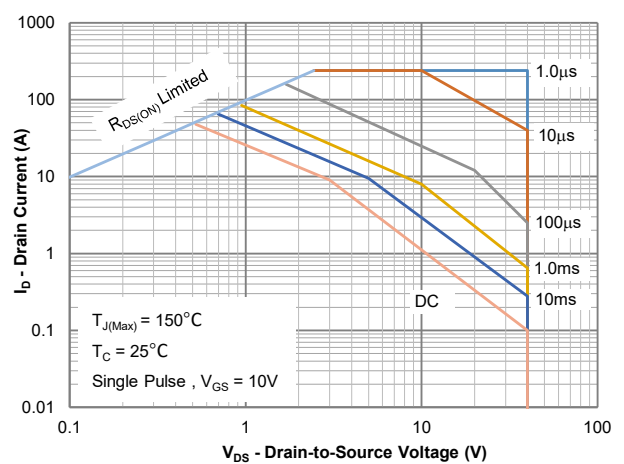

Figure 12: Safe Operating Area



Typical Electrical and Thermal Characteristics (Chip-1 & Chip-2)

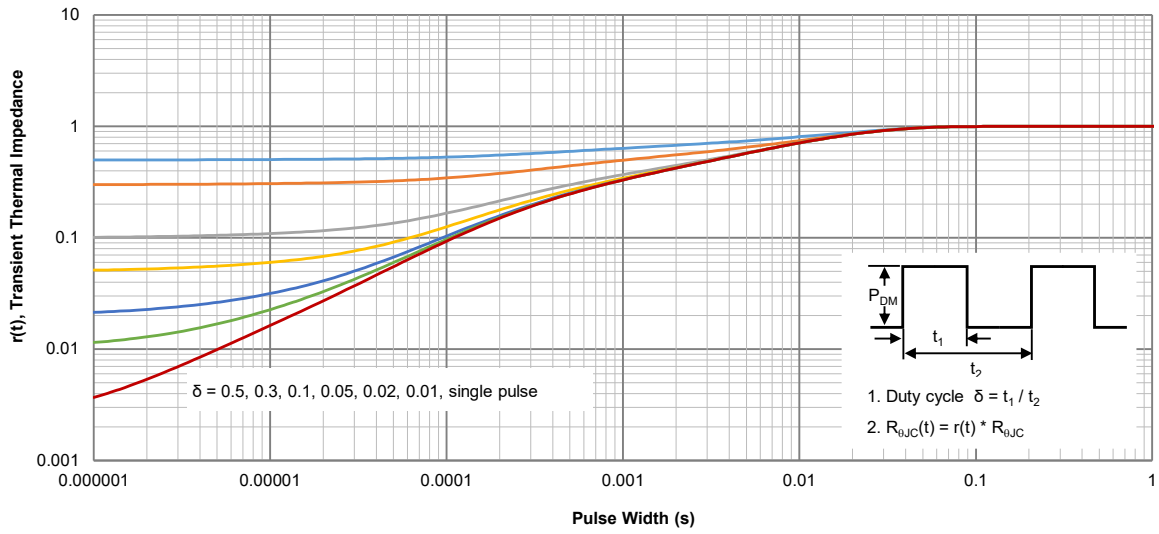
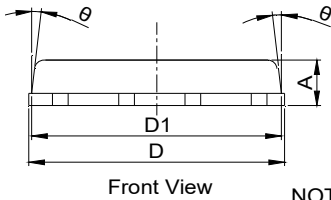
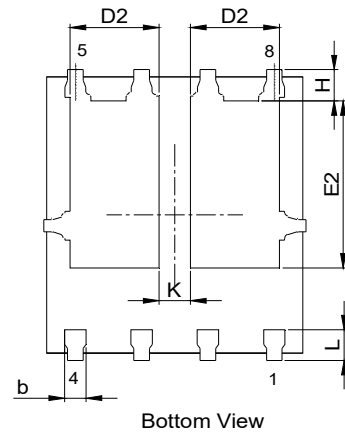
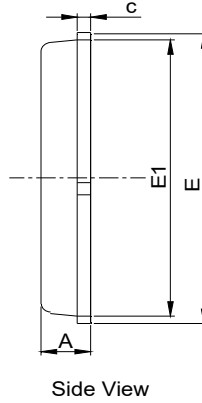
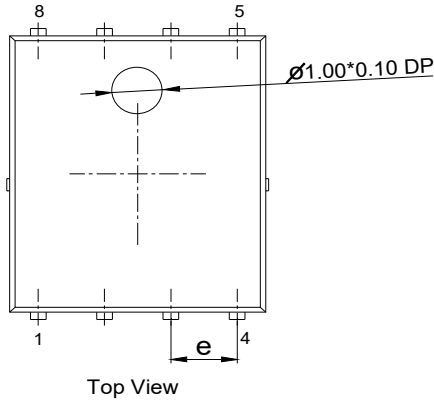

Figure 13: Normalized Maximum Transient Thermal Impedance



**PDFN5060-8L-D Package Outline**

**Package Outline**



**NOTES:**

1. DIMENSIONING AND TOLERANCING PER ASME Y14.5M, 1994.
2. ALL DIMENSIONS IN MILLIMETER (ANGLE IN DEGREE).
3. DIMENSIONS D1 AND E1 DO NOT INCLUDE MOLD FLASH PROTRUSIONS OR GATE BURRS.

DIM.	MILLIMETER		
	MIN.	NOM.	MAX.
A	0.90	1.00	1.10
b	0.20	--	0.51
c	0.21	0.25	0.34
D	4.85	5.00	5.15
D1	4.80	4.90	5.00
D2	1.50	--	1.80
E	5.90	6.00	6.10
E1	5.65	5.75	5.85
E2	3.38	3.48	3.78
e	1.27BSC		
H	0.41	--	0.75
L	0.45	0.60	0.75
K	0.60 REF		
$\theta$	0°	--	12°

**Recommended Soldering Footprint**

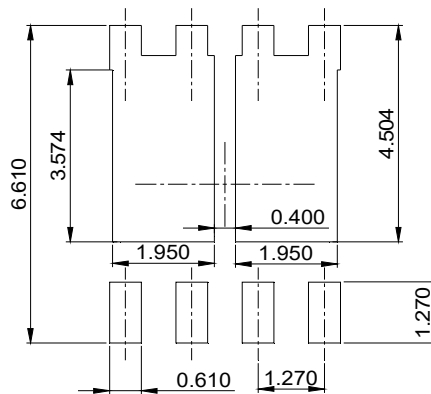

DIMENSIONS: MILLIMETERS